

RAPTOR



PLAQUE POUR LE LEVAGE D'ÉLÉMENTS EN BOIS

UNIVERSEL

RAPTOR peut être installé selon différentes configurations qui le rendent idéal pour les applications les plus courantes sur les chantiers de construction :

- 6 vis : résistance et capacité de charge maximales
 - 4 ou 2 vis : pour le levage et le transport de panneaux plus légers
- Les vis doivent être appliquées de manière symétrique.

POLYVALENTE

La plaque s'adapte à des configurations de déplacement très différents. Elle peut être utilisée pour travailler avec n'importe quelle inclinaison de la chaîne, efficace aussi bien en traction qu'en cisaillement, mais aussi dans des configurations intermédiaires.

CERTIFIÉE

Plaque certifiée selon la Directive Machines 2006/42/CE pour poids dépassant les 3 tonnes.

UTILISATION COMME POINT D'ANCRAGE TEMPORAIRE

Un produit - Deux fonctions. La plaque peut être utilisée comme dispositif de levage d'éléments en bois ainsi que comme point d'ancrage antichute temporaire.

VIS RÉUTILISABLES

Grâce à sa compatibilité avec les innovantes VG SPL, le système de levage permet la réutilisation des fixations même après la manutention. Ceci réduit les gaspillages et les coûts du projet tout en maintenant des normes de sécurité élevées.

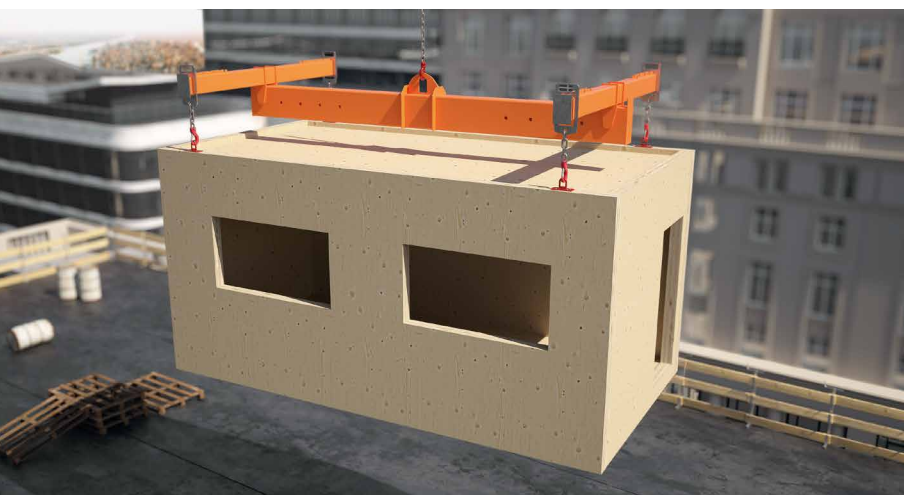

DOMAINES D'UTILISATION

- Panneaux plancher ou mur en CLT
- Poutre en bois massif ou bois lamellé-collé
- Parois préfabriquées en ossature bois
- Éléments structurels nervurés
- Structures modulaires préfabriquées
- Structures spéciales
- Point d'ancrage anti-chute temporaire

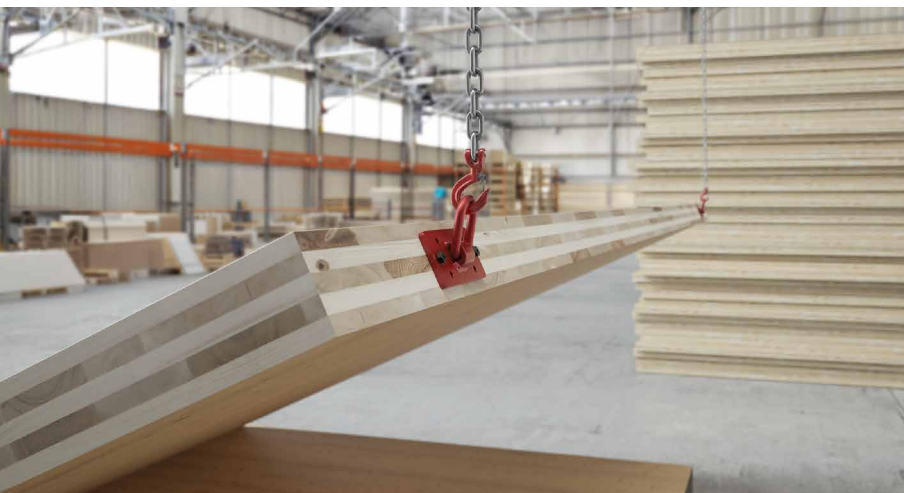

MATÉRIAU

La plaque d'acier robuste et le crochet de levage assurent un levage sûr ; le revêtement rouge améliore la protection et la visibilité sur le chantier, favorisant ainsi la sécurité sur le chantier.

CONFIGURATIONS

Les 6 trous permettent 3 options de montage avec différentes vis et assurent une installation optimale pour différentes conditions de levage et matériaux.

CODE

CODE	dimensions de la plaque	portée max.	vis adaptées	pcs.
			VGS PLATE Ø11 mm	
RAP220100	100 x 220 mm	3150 kg	HBS PLATE / HBS PLATE EVO Ø10 mm VGS Ø11 mm (+ HUS10)	1

DIMENSIONS

CODE	B	L	s	Ø	a	b	c	d
	[mm]	[mm]	[mm]	[mm]	[mm]	[mm]	[mm]	[mm]
RAP220100	100	220	10	13	60	125	180	107

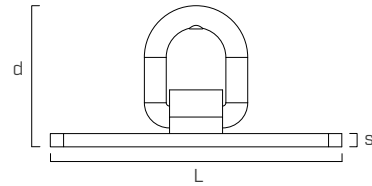
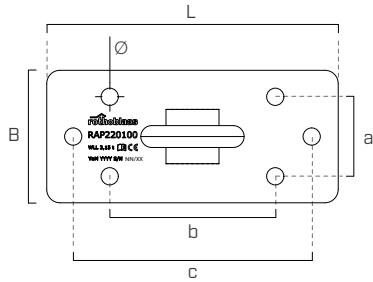

VIS COMPATIBLES

VGS PLATE

vis à tête tronconique hexagonale pour levage

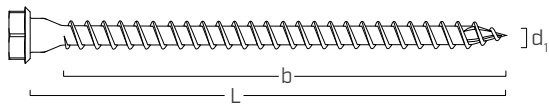

d ₁	CODE	L	b	pcs.
[mm]		[mm]	[mm]	
11 SW 17 TX 50	VGSP1160	60	50	25
	VGSP1180	80	70	25
	VGSP11100	100	90	25
	VGSP11120	120	110	25
	VGSP11140	140	130	25
	VGSP11160	160	150	25
	VGSP11180	180	170	25
	VGSP11200	200	190	25
	VGSP11240	240	230	25
	VGSP11280	280	270	25

VGS

connecteur à filetage total à tête fraisée

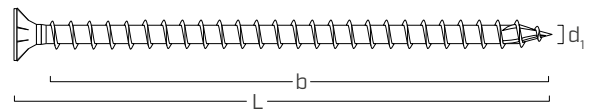

d ₁	CODE	L	b	pcs.
[mm]		[mm]	[mm]	
11 TX 50	VGS1180	80	70	25
	VGS11100	100	90	25
	VGS11125	125	115	25
	VGS11150	150	140	25
	VGS11175	175	165	25
	VGS11200	200	190	25
	VGS11225	225	215	25
	VGS11250	250	240	25
	VGS11275	275	265	25
	VGS11300	300	290	25
	VGS11325	325	315	25
	VGS11350	350	340	25
	VGS11375	375	365	25
	VGS11400	400	390	25

HBS PLATE - HBS PLATE EVO

vis à tête tronconique pour plaques

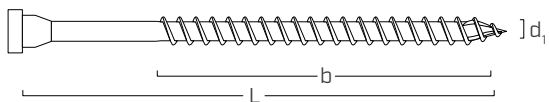

d ₁	CODE	L	b	pcs.
[mm]		[mm]	[mm]	
10 TX 40	HBSPLEVO1060	60	52	50
	HBSPL1080	80	60	50
	HBSPL10100	100	75	50
	HBSPL10120	120	95	50
	HBSPL10140	140	110	50
	HBSPL10160	160	130	50
	HBSPL10180	180	150	50

Vis VGS installable uniquement en combinaison avec une rondelle HUS.

HUS - rondelle tournée

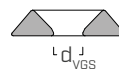

CODE	d _{VGS}	pcs.
	[mm]	
HUS10	11	50

INSTALLATION DE RAPTOR



HBSPL Ø10 $M_{ins,max} = 35 \text{ Nm}$
VGS | VGSPL Ø11 $M_{ins,max} = 30 \text{ Nm}$

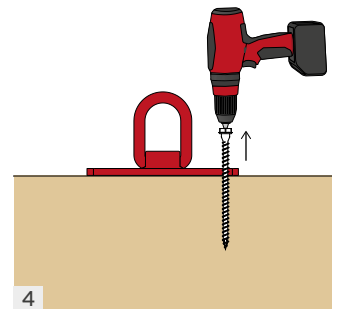
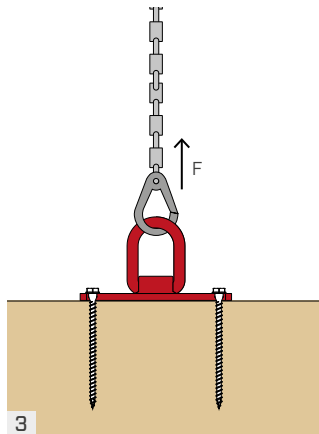
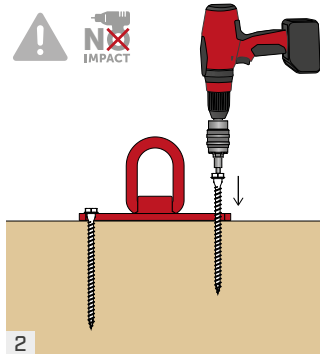
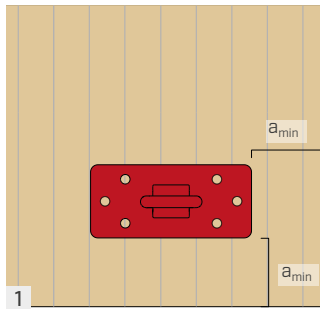

Lire attentivement les instructions d'utilisation et respecter les indications qui y sont contenues, telles que les distances minimales recommandées, les directions et les angles de levage ainsi que la capacité de charge maximale.

La longueur et la quantité des vis dépendent de l'application et du poids de l'élément. Faire attention au serrage correct, en respectant les couples de serrage indiqués dans les instructions d'installation relatives.

Fixer avec le crochet de la grue et soulever avec précaution l'élément. Faire attention aux angles et directions de levage autorisées et aux capacités de levage maximales correspondantes.

Une fois le levage terminé, dévisser et jeter les vis. Elles peuvent être utilisées pour une seule opération de manutention, à l'exception de la VGS PL, réutilisable dans des conditions spécifiques. Consulter les instructions.

DIRECTIONS DE CHARGE AUTORISÉES

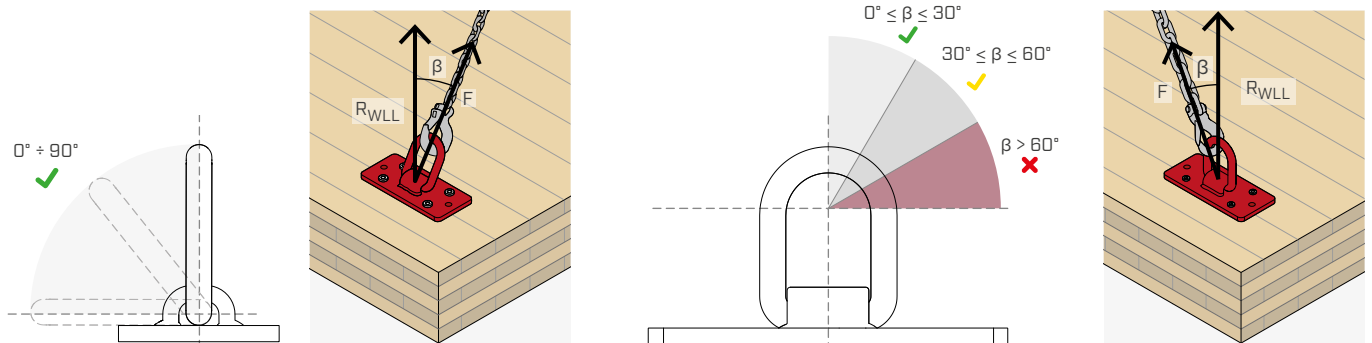

DISPOSITION POSSIBLE DES VIS

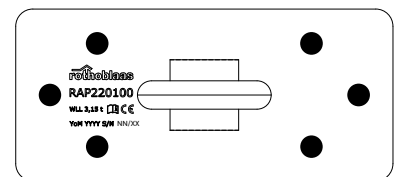
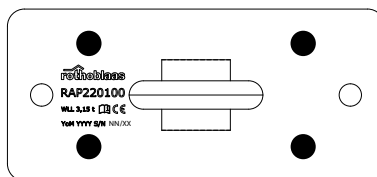
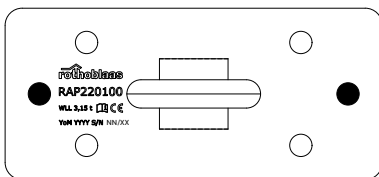

VGS PLATE

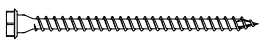

x2 VGS PLATE

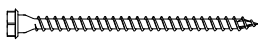

x4 VGS PLATE

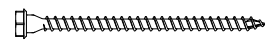

x6 VGS PLATE

HBS PLATE - HBS PLATE EVO

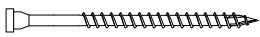

x2 HBS PLATE

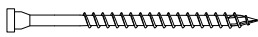

x4 HBS PLATE

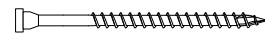

x6 HBS PLATE

VGS + HUS

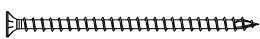

x2 VGS + x2 HUS

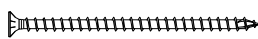

x4 VGS + x4 HUS

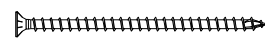

x6 VGS + x6 HUS

NOTES :

- La plaque RAPTOR doit être fixée avec des connecteurs homogènes, de même type (HBS PLATE, VGS PLATE ou VGS) et de même longueur. La même configuration doit être reproduite sur toutes les plaques utilisées sur l'élément à déplacer.

EXEMPLES D'APPLICATION

PANNEAU CLT HORIZONTAL

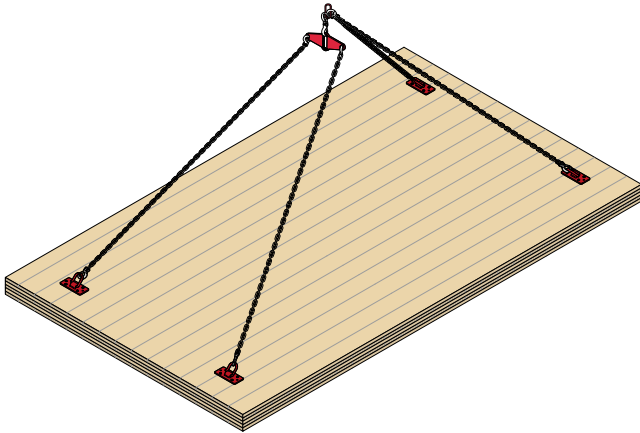

PANNEAU CLT VERTICAL NARROW FACE

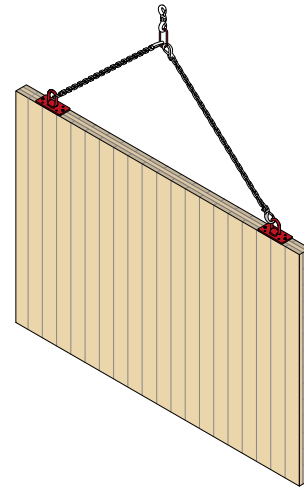

PANNEAU CLT VERTICAL LATERAL FACE

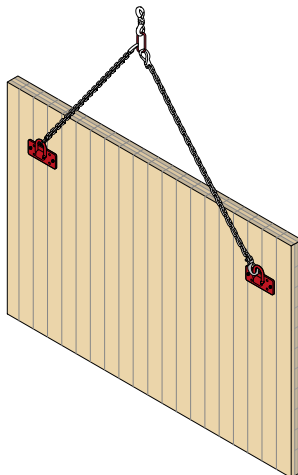

MUR À OSSATURE

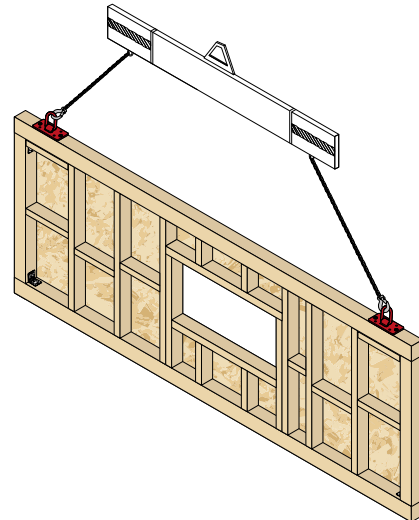

POUTRE HORIZONTALE

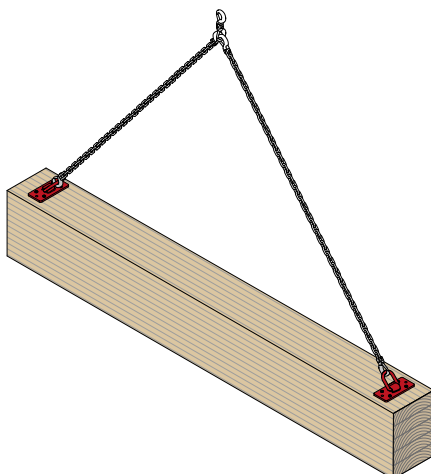

INFLUENCE DE LA RELATION ENTRE LA LONGUEUR DE LA VIS ET L'ÉPAISSEUR DE L'ÉLÉMENT

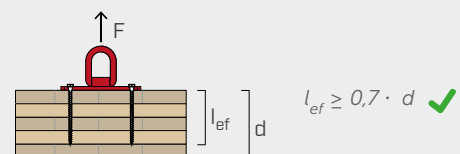

Pour les applications de levage avec une composante de charge perpendiculaire au fil du bois, afin d'atteindre la capacité maximale du système de levage, il est conseillé d'utiliser des vis d'une longueur supérieure à $0,7 \cdot d$ (d = profondeur de l'élément en bois) afin d'éviter les fissures de fendillement. Si ce rapport n'est pas respecté, il est possible de vérifier la présence de ruptures fragiles conformément à la norme DIN EN 1995-1-1/NA.

R_{WLL} = capacité de charge de référence pour un seul ancrage

R'_{WLL} = capacité de charge totale du système

β = angle de levage (angle entre vertical et chaîne)

VALEURS DE CHARGE | PANNEAU CLT HORIZONTAL

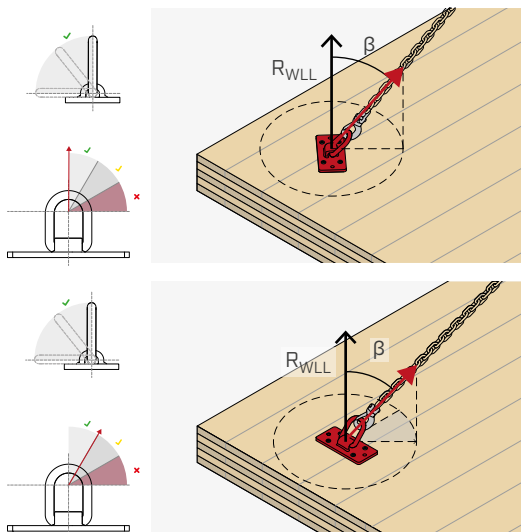
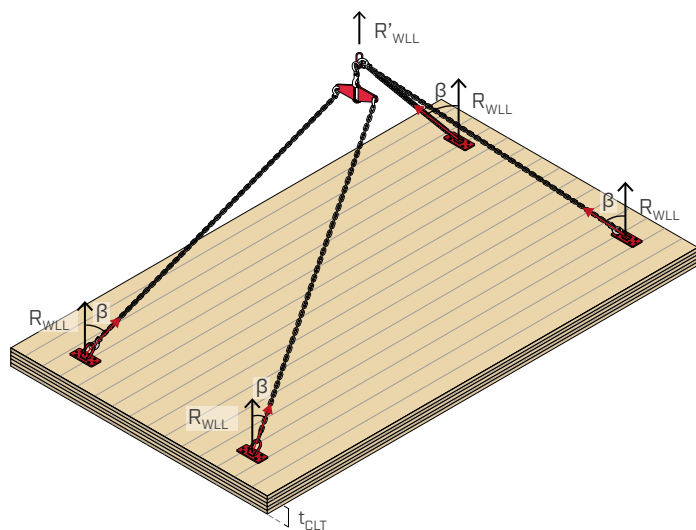









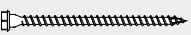

























CALCUL DE LA CAPACITÉ DE CHARGE TOTALE

$$R'_{WLL} = R_{WLL} \cdot n$$

R'_{WLL} = capacité de charge totale du système.
 R_{WLL} = capacité de charge de référence pour un seul ancrage (indiquée dans les tableaux).
 n = nombre d'ancrages entièrement porteurs.











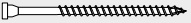















CAPACITÉ DE CHARGE MAXIMALE POUR UN POINT D' ANCRAGE AVEC VIS VGS PLATE

CODE vis VGS PLATE d x L [mm]	n° vis 	résistance R_{WLL} [kg]			
		$\beta = 0^\circ$ 	$0^\circ < \beta \leq 30^\circ$ 	$30^\circ < \beta \leq 45^\circ$ 	$45^\circ < \beta \leq 60^\circ$ 
VGSPL1160 11 x 60	2 	305	250	195	130
	4 	570	470	370	255
	6 	820	685	540	370
VGSPL1180 11 x 80	2 	425	340	260	175
	4 	795	650	500	335
	6 	1150	940	730	495
VGSPL11100 11 x 100	2 	550	430	320	210
	4 	1025	815	620	410
	6 	1480	1185	910	605
VGSPL11120 11 x 120	2 	670	505	365	235
	4 	1255	960	710	460
	6 	1805	1400	1045	680
VGSPL11140 11 x 140	2 	795	575	410	260
	4 	1480	1095	795	510
	6 	2135	1600	1170	755
VGSPL11160 11 x 160	2 	915	640	450	280
	4 	1710	1225	875	555
	6 	2465	1795	1285	820
VGSPL11180 11 x 180	2 	1040	700	485	305
	4 	1940	1350	945	595
	6 	2795	1975	1400	885
VGSPL11200 11 x 200	2 	1160	765	520	325
	4 	2165	1470	1020	635
	6 	3125	2155	1505	945
VGSPL11240 11 x 240	2 	1405	880	590	365
	4 	2625	1705	1160	715
	6 	3150	2290	1645	1050
VGSPL11280 11 x 280	2 	1650	995	660	400
	4 	3080	1930	1295	795
	6 	3150	2395	1765	1145

β = angle de levage

VALEURS DE CHARGE | PANNEAU CLT HORIZONTAL











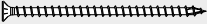



































CAPACITÉ DE CHARGE MAXIMALE POUR UN POINT D' ANCRAGE AVEC VIS HBS PLATE

CODE vis HBS PLATE/ HBS PLATE EVO d x L [mm]	n° vis 	résistance R_{WLL} [kg]			
		$\beta = 0^\circ$ 	$0^\circ < \beta \leq 30^\circ$ 	$30^\circ < \beta \leq 45^\circ$ 	$45^\circ < \beta \leq 60^\circ$ 
HBSPLEVO1060 10 x 60	2 	275	230	180	120
	4 	515	430	340	235
	6 	745	625	495	340
HBSPL1080 10 x 80	2 	330	275	215	145
	4 	620	520	410	280
	6 	895	755	600	410
HBSPL10100 10 x 100	2 	415	340	265	175
	4 	775	640	505	340
	6 	1120	930	735	500
HBSPL10120 10 x 120	2 	525	410	310	205
	4 	985	785	595	395
	6 	1420	1140	870	580
HBSPL10140 10 x 140	2 	610	465	340	220
	4 	1140	880	655	430
	6 	1645	1285	965	635
HBSPL10160 10 x 160	2 	720	525	380	240
	4 	1345	1010	735	475
	6 	1940	1470	1080	700
HBSPL10180 10 x 180	2 	830	590	415	260
	4 	1555	1130	805	515
	6 	2240	1650	1190	760

β = angle de levage

VALEURS DE CHARGE | PANNEAU CLT HORIZONTAL

CAPACITÉ DE CHARGE MAXIMALE POUR UN POINT D' ANCRAGE AVEC VIS VGS

CODE vis VGS + HUS10 d x L [mm]	n° vis 	résistance R_{WLL} [kg]			
		$\beta = 0^\circ$ 	$0^\circ < \beta \leq 30^\circ$ 	$30^\circ < \beta \leq 45^\circ$ 	$45^\circ < \beta \leq 60^\circ$ 
VGS1180 11 x 80	2 	375	305	235	155
	4 	705	580	450	300
	6 	1015	840	655	445
VGS11100 11 x 100	2 	500	395	300	200
	4 	935	755	580	385
	6 	1345	1095	845	565
VGS11125 11 x 125	2 	650	495	360	235
	4 	1220	940	700	455
	6 	1760	1370	1025	670
VGS11150 11 x 150	2 	805	580	415	260
	4 	1505	1110	800	515
	6 	2170	1620	1180	760
VGS11175 11 x 175	2 	960	660	460	290
	4 	1790	1270	900	570
	6 	2580	1860	1325	840
VGS11200 11 x 200	2 	1110	740	505	315
	4 	2075	1425	990	620
	6 	2990	2085	1465	920
VGS11225 11 x 225	2 	1265	815	550	340
	4 	2360	1570	1080	670
	6 	3150	2220	1570	990
VGS11250 11 x 250	2 	1415	885	595	365
	4 	2645	1715	1165	720
	6 	3150	2295	1650	1055
VGS11275 11 x 275	2 	1570	960	635	390
	4 	2935	1855	1250	770
	6 	3150	2360	1725	1115
VGS11300 11 x 300	2 	1725	1030	680	415
	4 	3150	1975	1330	815
	6 	3150	2420	1795	1170
VGS11325 11 x 325	2 	1805	1065	700	425
	4 	3150	2015	1360	840
	6 	3150	2420	1795	1170
VGS11350 11 x 350	2 	1805	1065	700	425
	4 	3150	2015	1360	840
	6 	3150	2420	1795	1170
VGS11375 11 x 375	2 	1805	1065	700	425
	4 	3150	2015	1360	840
	6 	3150	2420	1795	1170
VGS11400 11 x 400	2 	1805	1065	700	425
	4 	3150	2015	1360	840
	6 	3150	2420	1795	1170

β = angle de levage

NOTES :

- Lors du transport de panneaux CLT horizontaux, le rapport entre l'épaisseur du bois et la longueur des vis peut influencer la capacité portante.
- Les valeurs de capacité portante indiquées sont pour un seul point d'ancrage.
- Pour que tous les points de fixation soient considérés comme pleinement porteurs, il est nécessaire que la charge soit répartie uniformément sur tous les points de fixation au moyen de systèmes de compensation appropriés.
- Épaisseur minimum du mur: $t_{CLT} \geq 100$ mm.

VALEURS DE CHARGE | PANNEAU CLT VERTICAL NARROW FACE

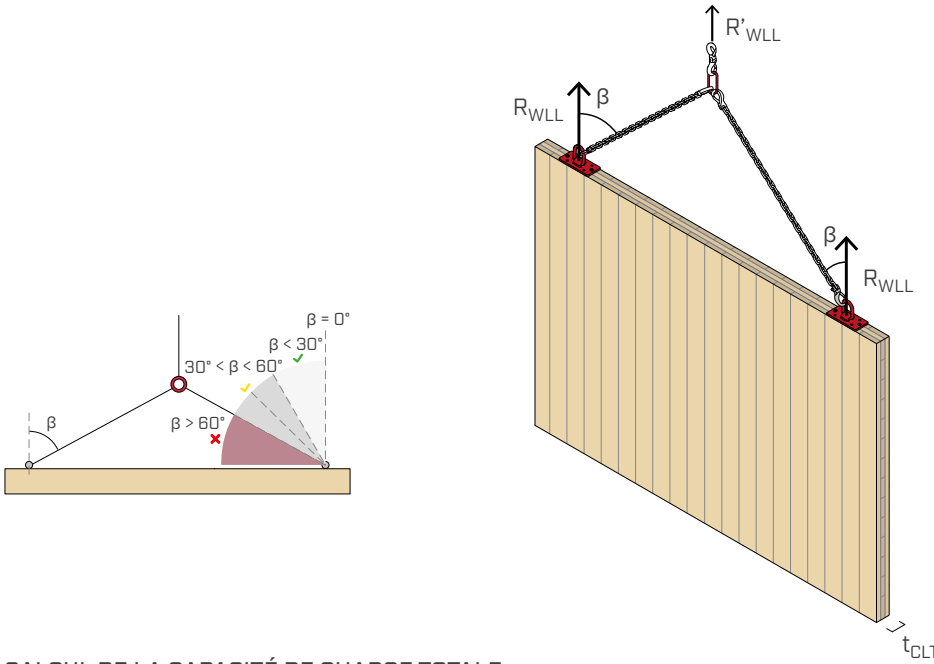









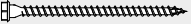





CALCUL DE LA CAPACITÉ DE CHARGE TOTALE

$$R'_{WLL} = R_{WLL} \cdot n$$

R'_{WLL} = capacité de charge totale du système.
 R_{WLL} = capacité de charge de référence pour un seul ancrage (indiquée dans les tableaux).
 n = nombre d'ancrages entièrement porteurs.

CAPACITÉ DE CHARGE MAXIMALE POUR UN POINT D' ANCRAGE AVEC VIS VGS PLATE

CODE vis VGS PLATE d x L [mm]	n° vis 	résistance R_{WLL} [kg]			
		$\beta = 0^\circ$ 	$0^\circ < \beta \leq 30^\circ$ 	$30^\circ < \beta \leq 45^\circ$ 	$45^\circ < \beta \leq 60^\circ$ 
VGSP1160 11 x 60	2 	215	170	125	80
VGSP1180 11 x 80	2 	295	225	165	110
VGSP11100 11 x 100	2 	370	275	200	130
VGSP11120 11 x 120	2 	445	330	240	150
VGSP11140 11 x 140	2 	515	380	270	175
VGSP11160 11 x 160	2 	585	415	295	185
VGSP11180 11 x 180	2 	655	455	315	200
VGSP11200 11 x 200	2 	725	490	335	210
VGSP11240 11 x 240	2 	860	555	375	230
VGSP11280 11 x 280	2 	995 ^(*)	620	415	255











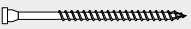

β = angle de levage

NOTES :

- Épaisseur minimum du mur: $t_{CLT} \geq 100$ mm.
- Les valeurs de capacité portante indiquées sont pour un seul point d'ancrage.
- Faire attention à ne pas insérer la vis dans la couche de colle.











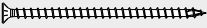







VALEURS DE CHARGE | PANNEAU CLT VERTICAL NARROW FACE

CAPACITÉ DE CHARGE MAXIMALE POUR UN POINT D' ANCRAGE AVEC VIS HBS PLATE

CODE vis HBS PLATE/ HBS PLATE EVO d x L [mm]	n° vis 	résistance R_{WLL} [kg]			
		$\beta = 0^\circ$ 	$0^\circ < \beta \leq 30^\circ$ 	$30^\circ < \beta \leq 45^\circ$ 	$45^\circ < \beta \leq 60^\circ$ 
HBSPLEVO1060 10 x 60	2 	200	155	115	75
HBSPL1080 10 x 80	2 	235	190	145	95
HBSPL10100 10 x 100	2 	290	225	170	110
HBSPL10120 10 x 120	2 	360	275	205	135
HBSPL10140 10 x 140	2 	410	315	235	150
HBSPL10160 10 x 160	2 	475	355	255	165
HBSPL10180 10 x 180	2 	545	390	280	175

β = angle de levage

CAPACITÉ DE CHARGE MAXIMALE POUR UN POINT D' ANCRAGE AVEC VIS VGS

CODE vis VGS + HUS10 d x L [mm]	n° vis 	résistance R_{WLL} [kg]			
		$\beta = 0^\circ$ 	$0^\circ < \beta \leq 30^\circ$ 	$30^\circ < \beta \leq 45^\circ$ 	$45^\circ < \beta \leq 60^\circ$ 
VGS1180 11 x 80	2 	265	205	155	100
VGS11100 11 x 100	2 	340	255	190	120
VGS11125 11 x 125	2 	430	320	230	150
VGS11150 11 x 150	2 	520	380	275	175
VGS11175 11 x 175	2 	610	430	305	190
VGS11200 11 x 200	2 	700	475	330	205
VGS11225 11 x 225	2 	785	520	355	220
VGS11250 11 x 250	2 	870 ^(*)	560	380	235
VGS11275 11 x 275	2 	955 ^(*)	600	400	245
VGS11300 11 x 300	2 	1035 ^(*)	640	425	260
VGS11325 11 x 325	2 	1120 ^(*)	675	450	275
VGS11350 11 x 350	2 	1200 ^(*)	715	470	285
VGS11375 11 x 375	2 	1280 ^(*)	750	490	300
VGS11400 11 x 400	2 	1365 ^(*)	785	515	310

β = angle de levage

(*) Dans le cas d'un levage depuis une position horizontale, la résistance pendant la phase de « basculement » est régulée. Dans ce cas, la résistance doit être réduite en appliquant un coefficient de réduction de 0,8.

VALEURS DE CHARGE | LEVAGE DU PANNEAU/PAROI EN CLT DEPUIS UNE POSITION HORIZONTALE

Pour le levage de parois en CLT d'une position horizontale à une position verticale, les capacités de charge indiquées dans les tableaux ci-dessus s'appliquent (PANNEAU CLT VERTICAL NARROW FACE), en appliquant, si nécessaire, le coefficient de réduction. Pendant la phase de « basculement », il faut toutefois veiller à ce que la face inférieure de la paroi soit fermement soutenue de manière à ce que la moitié de la charge soit transférée au sol.

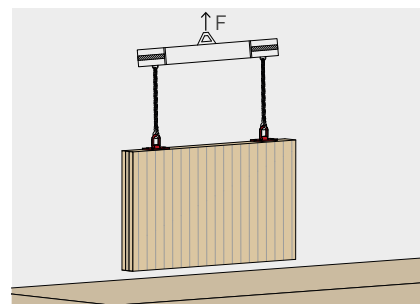
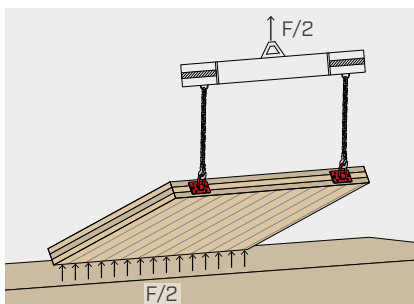
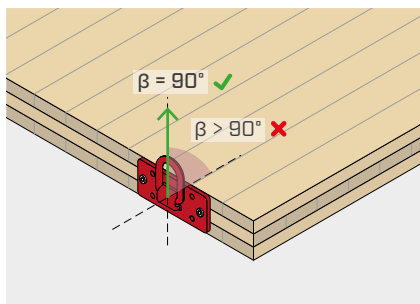
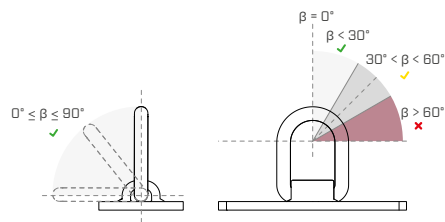

Gamme de levage

Des solutions conçues pour le levage et le déplacement en toute sécurité d'éléments en bois.

La gamme comprend des dispositifs conçus pour s'adapter aux différentes configurations de charge et aux modes d'utilisation sur les chantiers.



RAPTOR MINI



RAPTOR



RAPTOR MAXI



WASP

La documentation technique complète est disponible sur le site www.rothoblaas.fr



rothoblaas.it

VALEURS DE CHARGE | PANNEAU CLT VERTICAL LATERAL FACE

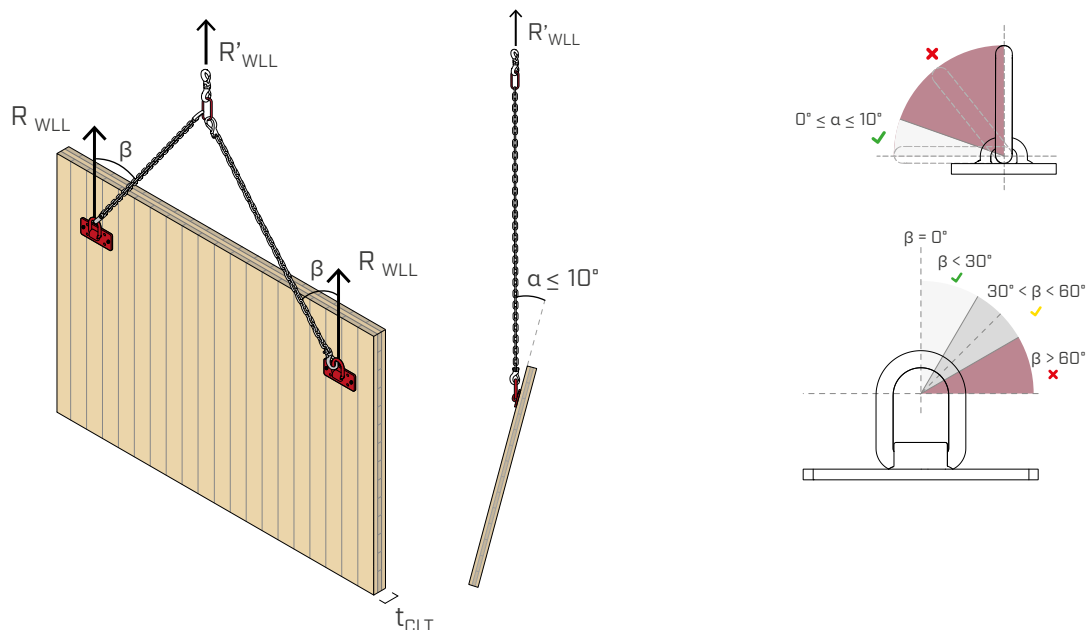









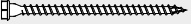

























CALCUL DE LA CAPACITÉ DE CHARGE TOTALE

$$R'_{WLL} = R_{WLL} \cdot n$$

R'_{WLL} = capacité de charge totale du système.
 R_{WLL} = capacité de charge de référence pour un seul ancrage (indiquée dans les tableaux).
 n = nombre d'ancrages entièrement porteurs.











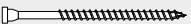















CAPACITÉ DE CHARGE MAXIMALE POUR UN POINT D' ANCRAGE AVEC VIS VGS PLATE

CODE vis VGS PLATE d x L [mm]	n° vis 	résistance R_{WLL} [kg]			
		$\beta = 0^\circ$ 	$0^\circ < \beta \leq 30^\circ$ 	$30^\circ < \beta \leq 45^\circ$ 	$45^\circ < \beta \leq 60^\circ$ 
VGSPL1160 11 x 60	2 	155	130	105	75
	4 	305	260	210	145
	6 	450	385	310	215
VGSPL1180 11 x 80	2 	205	175	140	100
	4 	405	345	280	195
	6 	595	510	410	285
VGSPL11100 11 x 100	2 	240	210	170	115
	4 	480	410	330	230
	6 	705	605	490	345
VGSPL11120 11 x 120	2 	285	240	195	135
	4 	560	480	385	270
	6 	825	710	575	400
VGSPL11140 11 x 140	2 	320	275	225	155
	4 	635	545	440	310
	6 	940	805	655	460
VGSPL11160 11 x 160	2 	340	295	240	165
	4 	680	585	470	330
	6 	1005	860	700	490
VGSPL11180 11 x 180	2 	360	310	250	175
	4 	720	620	500	350
	6 	1065	915	745	520
VGSPL11200 11 x 200	2 	380	330	265	185
	4 	760	650	530	370
	6 	1125	965	785	550
VGSPL11240 11 x 240	2 	420	360	295	205
	4 	835	720	580	410
	6 	1240	1065	865	610
VGSPL11280 11 x 280	2 	455	395	320	225
	4 	905	780	635	445
	6 	1350	1165	945	665

β = angle de levage

VALEURS DE CHARGE | PANNEAU CLT VERTICAL LATERAL FACE











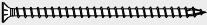

















CAPACITÉ DE CHARGE MAXIMALE POUR UN POINT D' ANCRAGE AVEC VIS HBS PLATE

CODE vis HBS PLATE/ HBS PLATE EVO d x L [mm]	n° vis 	résistance R_{WLL} [kg]			
		$\beta = 0^\circ$ 	$0^\circ < \beta \leq 30^\circ$ 	$30^\circ < \beta \leq 45^\circ$ 	$45^\circ < \beta \leq 60^\circ$ 
HBSPLEVO1060 10 x 60	2 	145	125	100	70
	4 	290	245	200	140
	6 	425	365	295	205
HBSPL1080 10 x 80	2 	180	155	125	85
	4 	360	305	245	170
	6 	525	450	360	250
HBSPL10100 10 x 100	2 	215	180	145	100
	4 	420	360	290	200
	6 	615	525	425	295
HBSPL10120 10 x 120	2 	250	215	175	120
	4 	495	425	340	240
	6 	730	625	505	355
HBSPL10140 10 x 140	2 	285	245	195	135
	4 	560	480	390	270
	6 	825	710	570	400
HBSPL10160 10 x 160	2 	305	260	210	145
	4 	605	515	420	290
	6 	890	765	620	435
HBSPL10180 10 x 180	2 	325	280	225	155
	4 	640	550	445	310
	6 	950	815	660	465

β = angle de levage

VALEURS DE CHARGE | PANNEAU CLT VERTICAL LATERAL FACE

CAPACITÉ DE CHARGE MAXIMALE POUR UN POINT D' ANCRAGE AVEC VIS VGS

CODE vis VGS + HUS10 d x L [mm]	n° vis 	résistance R_{WLL} [kg]			
		$\beta = 0^\circ$ 	$0^\circ < \beta \leq 30^\circ$ 	$30^\circ < \beta \leq 45^\circ$ 	$45^\circ < \beta \leq 60^\circ$ 
VGS1180 11 x 80	2 	190	160	130	90
	4 	375	320	260	180
	6 	550	470	380	265
VGS11100 11 x 100	2 	225	195	155	110
	4 	450	385	310	215
	6 	660	565	460	320
VGS11125 11 x 125	2 	275	235	190	135
	4 	545	470	380	265
	6 	805	690	560	395
VGS11150 11 x 150	2 	325	280	225	155
	4 	640	550	445	310
	6 	945	810	660	460
VGS11175 11 x 175	2 	350	300	245	170
	4 	695	595	480	335
	6 	1025	880	715	500
VGS11200 11 x 200	2 	375	320	260	180
	4 	745	640	515	365
	6 	1100	945	770	540
VGS11225 11 x 225	2 	400	340	280	195
	4 	790	680	550	385
	6 	1170	1010	820	575
VGS11250 11 x 250	2 	420	365	295	205
	4 	840	720	585	410
	6 	1245	1070	870	610

β = angle de levage

NOTES :

- Les valeurs de capacité portante indiquées sont pour un seul point d'ancrage.
- Épaisseur minimum du mur : $t_{CLT} \geq 80$ mm.
- En raison de la fixation sur un seul côté, la paroi s'inclinera légèrement. Il est

conseillé de fixer les plaques de transport le plus haut possible, en respectant des distances minimales par rapport aux extrémités, afin de limiter le phénomène. Il est conseillé de limiter l'angle d'inclinaison à moins de 10° par rapport à la verticale.

VALEURS DE CHARGE | POUTRE HORIZONTALE ET PAROI À OSSATURE

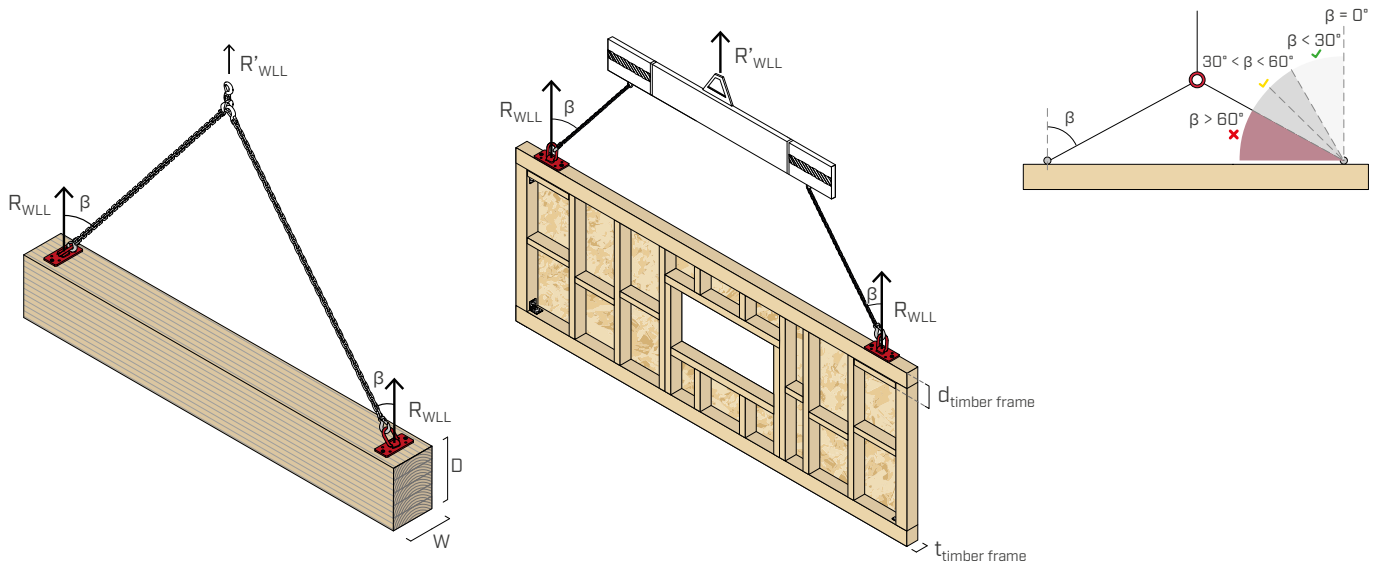

CALCUL DE LA CAPACITÉ DE CHARGE TOTALE











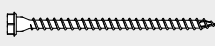























$$R'_{WLL} = R_{WLL} \cdot n$$

R'_{WLL} = capacité de charge totale du système.

R_{WLL} = capacité de charge de référence pour un seul ancrage (indiquée dans les tableaux).

n = nombre d'ancrages entièrement porteurs.











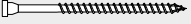















CAPACITÉ DE CHARGE MAXIMALE POUR UN POINT D' ANCRAGE AVEC VIS VGS PLATE

CODE vis VGS PLATE d x L [mm]	n° vis 	résistance R_{WLL} [kg]			
		$\beta = 0^\circ$ 	$0^\circ < \beta \leq 30^\circ$ 	$30^\circ < \beta \leq 45^\circ$ 	$45^\circ < \beta \leq 60^\circ$ 
VGSPL1160 11 x 60	2 	330	270	210	140
	4 	615	510	400	270
	6 	885	740	585	400
VGSPL1180 11 x 80	2 	460	370	280	185
	4 	860	700	540	365
	6 	1240	1015	790	535
VGSPL11100 11 x 100	2 	590	460	345	225
	4 	1105	875	665	440
	6 	1595	1275	970	645
VGSPL11120 11 x 120	2 	725	540	395	250
	4 	1355	1030	760	495
	6 	1950	1505	1115	730
VGSPL11140 11 x 140	2 	855	615	435	275
	4 	1600	1175	850	545
	6 	2305	1720	1250	805
VGSPL11160 11 x 160	2 	990	685	480	300
	4 	1845	1315	935	590
	6 	2660	1925	1375	875
VGSPL11180 11 x 180	2 	1120	750	520	325
	4 	2095	1450	1015	635
	6 	3015	2120	1495	945
VGSPL11200 11 x 200	2 	1255	820	560	345
	4 	2340	1575	1090	680
	6 	3150	2235	1585	1005
VGSPL11240 11 x 240	2 	1515	945	630	385
	4 	2830	1825	1240	765
	6 	3150	2360	1720	1110
VGSPL11280 11 x 280	2 	1780	1065	705	430
	4 	3150	2025	1370	845
	6 	3150	2420	1795	1170

β = angle de levage

VALEURS DE CHARGE | POUTRE HORIZONTALE ET PAROI À OSSATURE











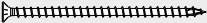



































CAPACITÉ DE CHARGE MAXIMALE POUR UN POINT D' ANCRAGE AVEC VIS HBS PLATE

CODE vis HBS PLATE/ HBS PLATE EVO d x L [mm]	n° vis 	résistance R_{WLL} [kg]			
		$\beta = 0^\circ$ 	$0^\circ < \beta \leq 30^\circ$ 	$30^\circ < \beta \leq 45^\circ$ 	$45^\circ < \beta \leq 60^\circ$ 
HBSPLEVO1060 10 x 60	2 	300	250	200	135
	4 	560	475	380	265
	6 	805	685	550	385
HBSPL1080 10 x 80	2 	360	300	240	165
	4 	670	570	460	320
	6 	965	825	665	465
HBSPL10100 10 x 100	2 	450	370	290	200
	4 	840	705	560	385
	6 	1210	1020	810	555
HBSPL10120 10 x 120	2 	570	450	340	225
	4 	1060	855	655	440
	6 	1530	1240	955	640
HBSPL10140 10 x 140	2 	660	505	375	240
	4 	1230	965	725	475
	6 	1775	1400	1055	695
HBSPL10160 10 x 160	2 	780	575	415	265
	4 	1455	1100	805	520
	6 	2095	1600	1180	765
HBSPL10180 10 x 180	2 	900	640	455	285
	4 	1680	1230	885	565
	6 	2420	1790	1295	830

β = angle de levage

VALEURS DE CHARGE | POUTRE HORIZONTALE ET PAROI À OSSATURE

CAPACITÉ DE CHARGE MAXIMALE POUR UN POINT D' ANCRAGE AVEC VIS VGS

CODE vis VGS + HUS10 d x L [mm]	n° vis 	résistance R_{WLL} [kg]			
		$\beta = 0^\circ$ 	$0^\circ < \beta \leq 30^\circ$ 	$30^\circ < \beta \leq 45^\circ$ 	$45^\circ < \beta \leq 60^\circ$ 
VGS1180 11 x 80	2 	405	330	260	170
	4 	760	625	500	325
	6 	1100	905	725	480
VGS11100 11 x 100	2 	540	430	335	215
	4 	1010	810	645	415
	6 	1455	1180	935	610
VGS11125 11 x 125	2 	705	530	395	250
	4 	1315	1010	765	485
	6 	1895	1470	1120	715
VGS11150 11 x 150	2 	870	620	450	280
	4 	1625	1190	880	550
	6 	2340	1740	1285	810
VGS11175 11 x 175	2 	1035	710	500	310
	4 	1935	1360	980	605
	6 	2785	1995	1445	900
VGS11200 11 x 200	2 	1200	790	550	335
	4 	2240	1525	1080	660
	6 	3150	2210	1580	980
VGS11225 11 x 225	2 	1365	870	600	365
	4 	2550	1685	1175	715
	6 	3150	2290	1665	1050
VGS11250 11 x 250	2 	1530	950	645	390
	4 	2855	1840	1270	770
	6 	3150	2365	1750	1115
VGS11275 11 x 275	2 	1695	1025	690	415
	4 	3150	1985	1360	820
	6 	3150	2420	1825	1170
VGS11300 11 x 300	2 	1805	1075	720	435
	4 	3150	2035	1400	855
	6 	3150	2420	1870	1170
VGS11325 11 x 325	2 	1805	1075	720	435
	4 	3150	2035	1400	855
	6 	3150	2420	1870	1170
VGS11350 11 x 350	2 	1805	1075	720	435
	4 	3150	2035	1400	855
	6 	3150	2420	1870	1170
VGS11375 11 x 375	2 	1805	1075	720	435
	4 	3150	2035	1400	855
	6 	3150	2420	1870	1170
VGS11400 11 x 400	2 	1805	1075	720	435
	4 	3150	2035	1400	855
	6 	3150	2420	1870	1170

β = angle de levage

NOTES :

- Pour les capacités de charge dans les applications Ossature Bois, il faut se référer au tableau des capacités de charge pour les « poutres horizontales » en tenant compte des facteurs de réduction possibles pour les différentes qualités de bois.
- Pour le calcul, la masse volumique des éléments en bois a été estimée à $\rho_k = 385 \text{ kg/m}^3$.
- Les valeurs de capacité portante indiquées sont pour un seul point d'ancrage.
- Base minimum de la poutre $W \geq 240 \text{ mm}$.
- Base minimum de la poutre $D \geq 80 \text{ mm}$.
- Largeur minimale de la structure en Timber Frame $t_{\text{timber frame}} \geq 100 \text{ mm}$.
- Épaisseur minimale de la structure en Timber Frame $d_{\text{timber frame}} \geq 80 \text{ mm}$.

DISTANCES MINIMALES

PLANCHER CLT

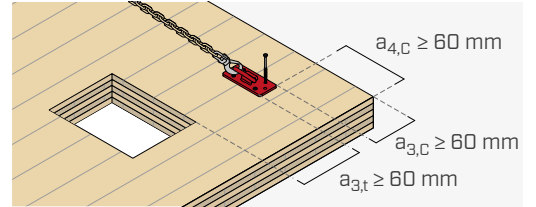
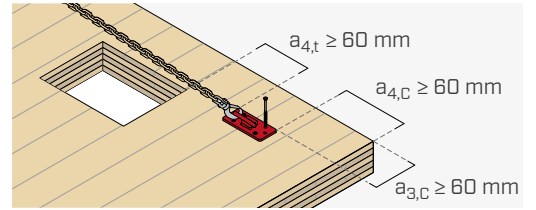
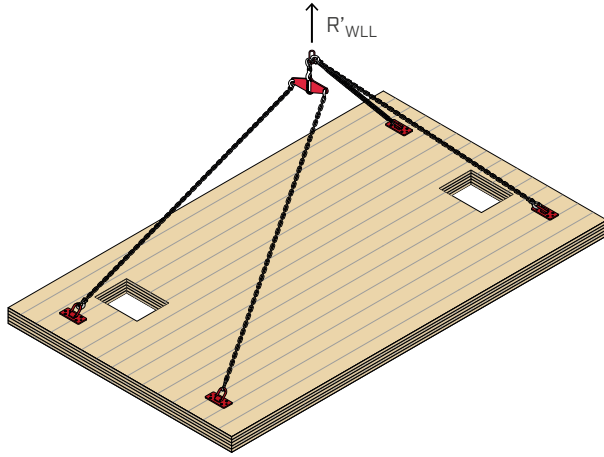

PARDI EN CLT VERTICALE LATERAL FACE

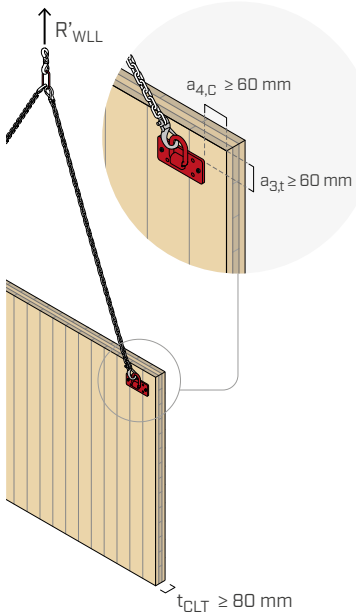

PARDI EN CLT VERTICALE NARROW FACE

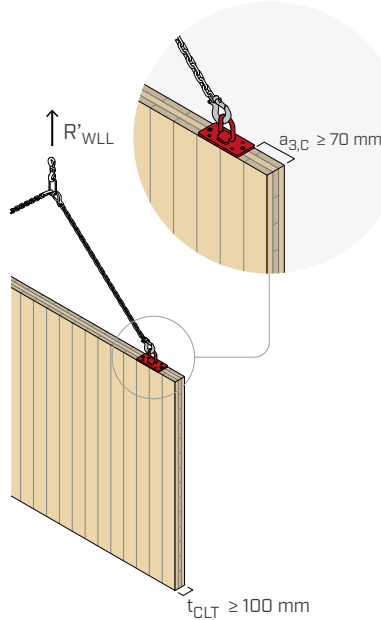

MUR À OSSATURE

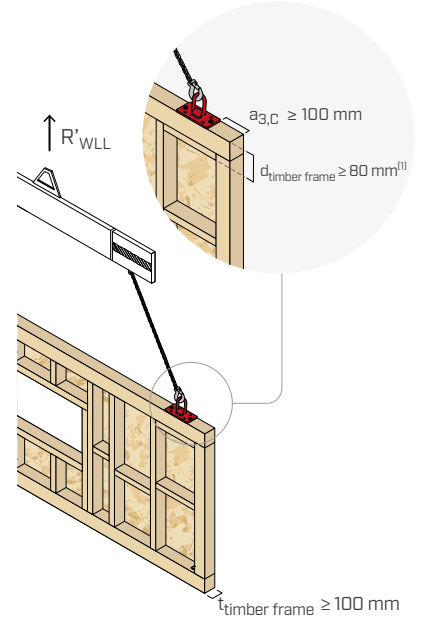

POUTRE HORIZONTALE - 0° FIXATION À 2 VIS

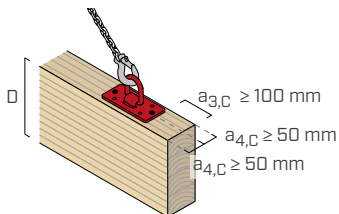

POUTRE HORIZONTALE - 90° FIXATION À 2 & 6 VIS

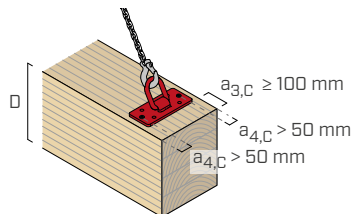

POUTRE HORIZONTALE - 90° FIXATION À 4 VIS

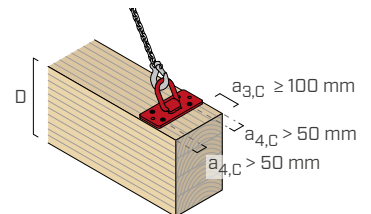

PLANCHERS NERVURÉS

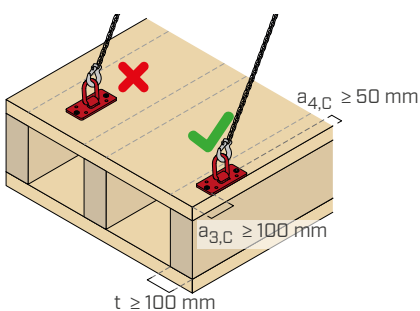

NOTES :

⁽¹⁾ Pour les poutres d'épaisseur réduite, évaluer l'insertion d'un élément de renforcement en bois afin d'atteindre l'épaisseur minimale fixable.

- Les distances minimales sont conformes à l'ATE-11/0030 et basées sur des essais. Elles sont valables sauf indication contraire fourni dans cette fiche technique.
- Les distances minimales indiquées sont valables pour des vis insérées sans pré-perçage.

ENTRETIEN

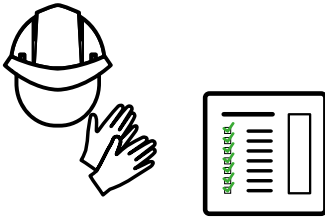

Toujours suivre les instructions du manuel d'utilisation.

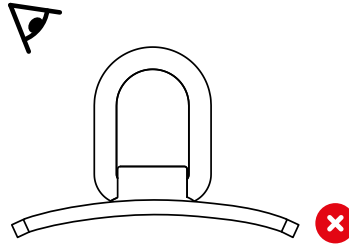

Contrôle visuel avant chaque utilisation. En cas de défaut, le produit ne doit plus être utilisé.

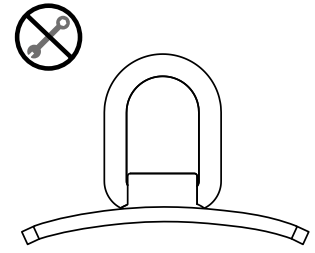

Ne pas effectuer de réparation !

DIMENSIONS À CONTRÔLER

CODE	\varnothing_{\max} [mm]	a_{\min} [mm]
RAP220100	13,5	16,0

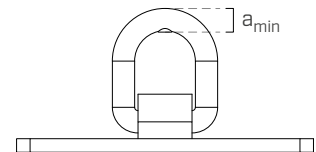
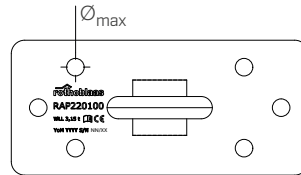

PRINCIPES GÉNÉRAUX :

- Le choix de la longueur du connecteur est à évaluer au cas par cas en fonction des dimensions de l'élément en bois, du mode de positionnement du connecteur, de l'angle de levage, de la taille de la charge à soulever et de la disposition de la plaque de levage. Dans tous les cas, il est recommandé d'utiliser des connecteurs plus longs possibles afin que la pointe ne dépasse pas de l'élément à soulever.
- Les valeurs de capacité de charge fournies sont basées sur des calculs effectués selon la norme EN 1995-1-1/NA conformément à l'ATE-11/0030 et sur des résultats d'essais effectués. Un facteur de sécurité de 4,0 a été appliqué aux valeurs fournies conformément à la Directive des Machines.
- Les vérifications d'éventuelles baisses de résistance dues à des ruptures fragiles liées à la géométrie de l'élément à soulever et au positionnement de la plaque et des connecteurs doivent être effectuées séparément.
- En phase de calcul, une masse volumique des éléments en bois égale à $\rho_k = 385 \text{ kg/m}^3$, des éléments en CLT égale à $\rho_k = 350 \text{ kg/m}^3$ a été considérée. Pour des valeurs de ρ_k différentes, les résistances indiquées dans le tableau peuvent être converties avec le coefficient k_{dens} . La valeur calculée ne doit jamais dépasser la capacité maximale de la plaque de **3150 kg**.

$$R'_{WLL} = \min(k_{\text{dens}} \cdot R'_{WLL}; 3150 \text{ kg})$$

$\rho_{g,k}$ [kg/m ³]	310	330	350	380	385	405	425	430	440
C-GL	C16	C20	C24	C30	GL24h	GL26h	GL28h	GL30h	GL32h
k_{dens}	0,80	0,85	0,90	0,98	1,00	1,02	1,05	1,05	1,07

$\rho_{g,k}$ [kg/m ³]	310	330	350	380	385	405	425	430	440
C-GL	C16	C20	C24	C30	GL24h	GL26h	GL28h	GL30h	GL32h
k_{dens}	0,88	0,94	1,00	1,04	1,05	1,07	1,10	1,11	1,12

Les valeurs de résistance ainsi déterminées pourraient différer, en faveur de la sécurité, de celles résultant d'un calcul exact.

- L'utilisation de la plaque de levage est réservée exclusivement au personnel qualifié. Le manuel d'utilisation (fourni avec le produit et disponible sur le site www.rothoblaas.fr) doit être lu et compris avant utilisation. Il est nécessaire de se conformer aux informations et aux instructions qui y sont contenues. En cas de doute, contacter le Bureau technique de Rothoblaas avant l'utilisation.
- Pour le calcul de la capacité de charge de la plaque de levage dans des configurations d'installation autres que celles présentées ici, veuillez contacter le Bureau Technique Rothoblaas.
- Les valeurs indiquées dans la fiche technique pour la plaque de transport fixée avec des vis HBS PLATE ont été calculées en tenant compte de la géométrie et des paramètres mécaniques de la version HBS PL. Pour les capacités de charge de la plaque de transport fixée avec la vis HBS P, il faut se référer à la version précédente de la fiche technique fournie sur le site. En alternative, veuillez contacter le Bureau Technique pour une assistance supplémentaire.
- Pour des raisons de sécurité, les vis HBSPL et VGS doivent être utilisées une seule fois. Une fois les opérations de levage terminées, les vis doivent être dévissées et éliminées de manière appropriée. Seule la vis VGS PL peut être réutilisée pour le transport sous certaines conditions. Veuillez consulter les instructions spécifiques de la vis, disponibles sur le site www.rothoblaas.com
- L'utilisation de la visseuse à impulsions / percussion est interdite. Respecter l'angle d'insertion à l'aide d'un trou pilote et/ou d'un gabarit d'installation. Éviter les plis. Vérifier le serrage. Nous conseillons l'utilisation de visseuses à contrôle de couple, par exemple avec TORQUE LIMITER. En alternative, serrer à l'aide d'une clé dynamométrique.
- Les capacités de charge fournies sont évaluées dans le cas d'une plaque fixée avec des vis insérées sans pré-perçage ; si les vis sont insérées avec pré-perçage, la résistance peut être considérée comme équivalente.